

# Sky Tunnel

## Large Commercial Daylighting Systems

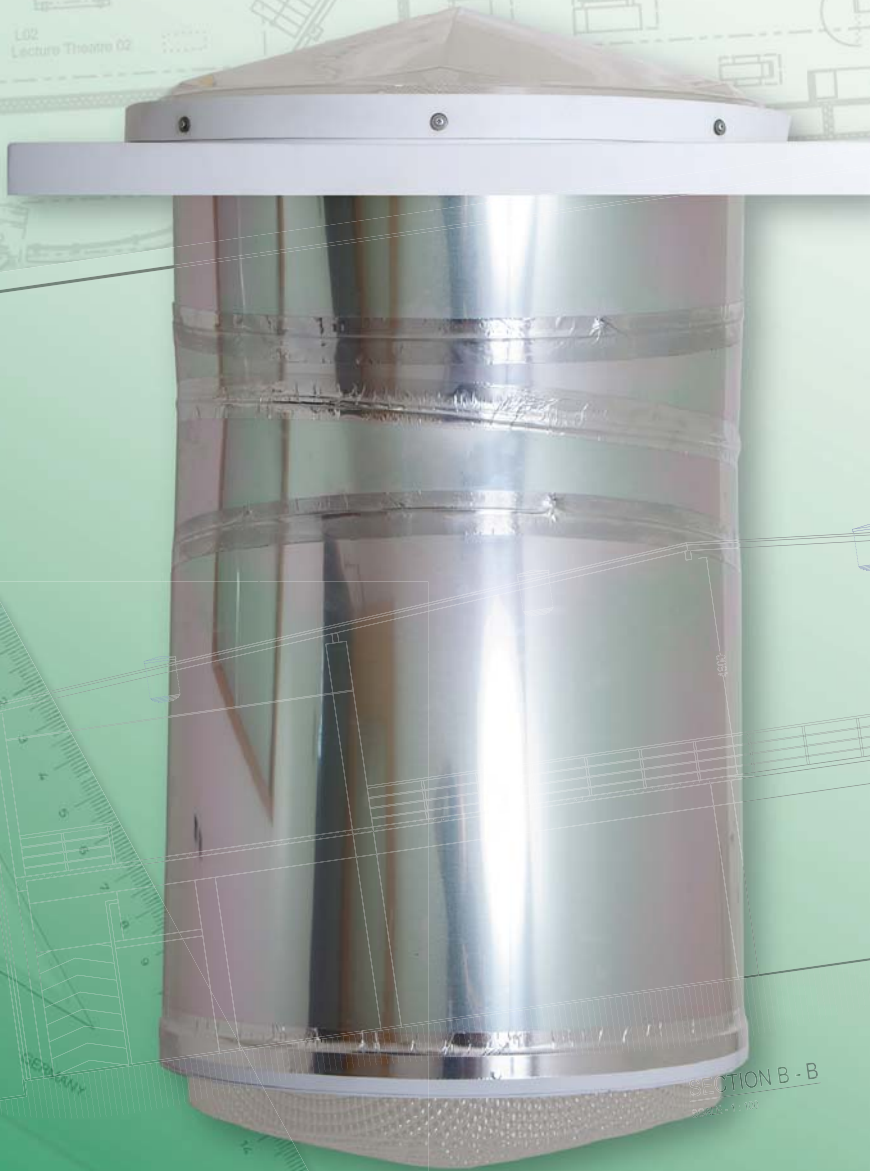

SKY TUNNEL RS750

SUSPENDED CEILING

3000

3000

SECTION B - B



# Sky Tunnel™ Large Commercial with Rigid98 Tube

## COMPONENT SPECIFICATIONS

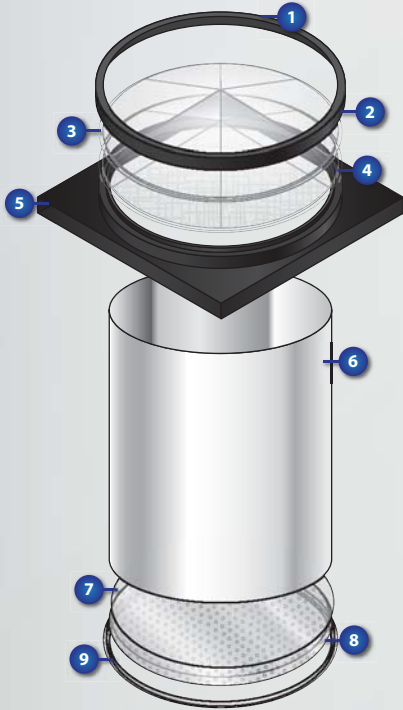

- 1) **DOMESURROUND** – Fibre re-inforced Resin to hold dome/s in place.
- 2) **SCREWS:** Class 3 Corrosion Resistant to fasten Dome Surround to Roof Frame.
- 3) **DOMESURROUND:** Specialised UV Grade Polycarbonate (LEXAN) or PMMA (Acrylic)
- 4) **DOMESURROUND:** Optional Double Glazing - 3mm PMMA (Acrylic) with texture.
- 5) **ROOF FRAME:** Fibre re-inforced Resin designed for Hob/Curb Mount.
- 6) **RIGID98 TUBE:** Alanod Miro Silver - Upper Rings, Angle Adaptors & 625mm Lengths.
- 7) **DIFFUSER:** Optional Double glazing - 3mm PMMA (Acrylic).
- 8) **DIFFUSER:** Moulded 4.5mm PMMA (Acrylic) with texture.
- 9) **DIFFUSER FRAME:** White Powdercoated Aluminium to hold diffuser in place.



800mm Sky Tunnel installed in Steelfab Asia Factory.

**Available in the following diameters:  
750mm, 800mm, 900mm & 1000mm**

Distributed by:



Manufactured by:



**SG Eco  
Industries Inc.**



Building 15A Philexcel Business Park, M-Roxas Highway,  
Clark Freeport Zone, Pampanga, PHILIPPINES

**Ph:** (045) 499 1037    **Fx:** (045) 499 1443

**International:** + 63 45 499 1037

**Email:** office@eco.ph    **Web:** www.eco.ph